

(No Model.)

2 Sheets—Sheet 1.

J. T. EVELY.
EXPANDING MANDREL.

No. 436,223.

Patented Sept. 9, 1890.

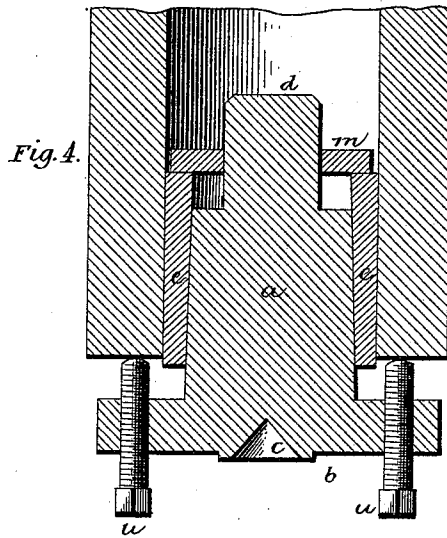
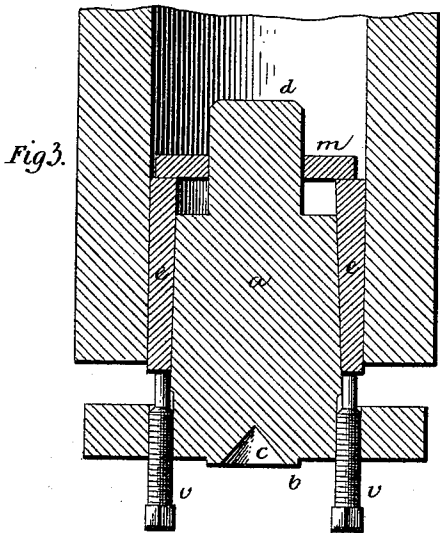
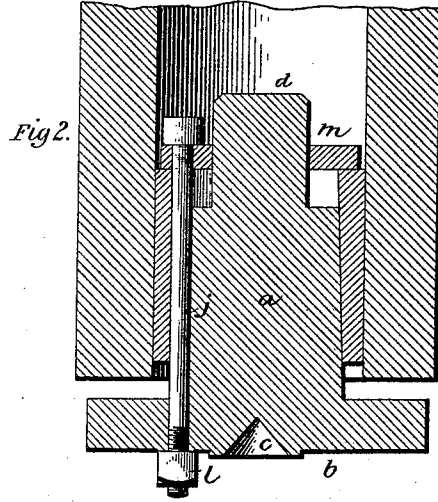
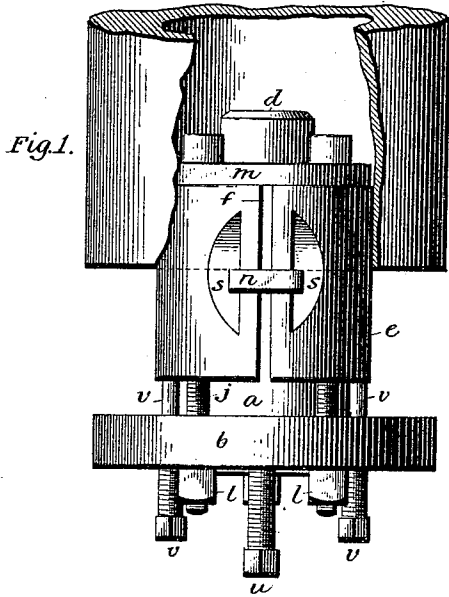

WITNESSES:

Wm. S. Norton
J. H. Brown

INVENTOR

John T. Evely
BY *W. A. Dudley*
ATTORNEY.

(No Model.)

2 Sheets—Sheet 2.

J. T. EVELY.
EXPANDING MANDREL.

No. 436,223.

Patented Sept. 9, 1890.

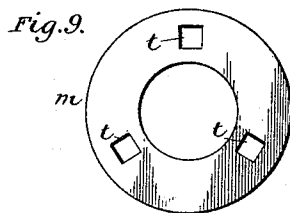
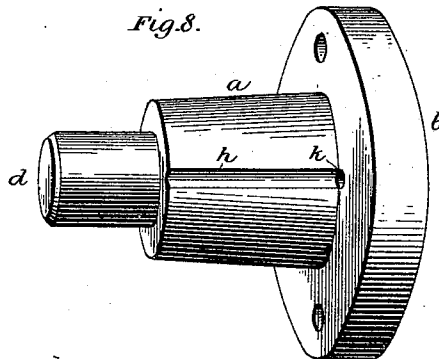
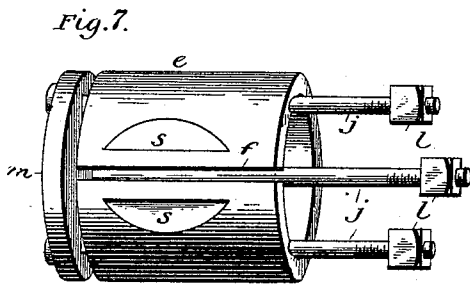
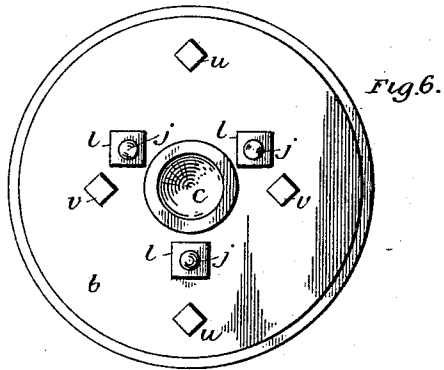
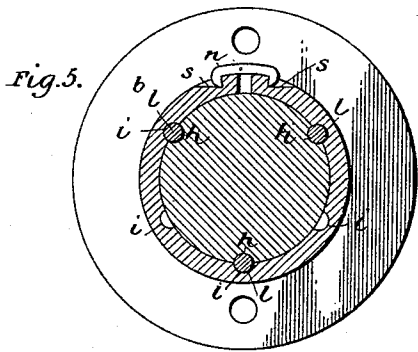

WITNESSES:

Wm. Norton
F. H. Brown

INVENTOR
John T. Evely
BY
W. W. Dudley
ATTORNEY.

UNITED STATES PATENT OFFICE.

JOHN T. EVELY, OF WASHINGTON, DISTRICT OF COLUMBIA, ASSIGNOR OF ONE-HALF TO WILLIAM W. DUDLEY AND FRANK L. BROWNE, OF SAME PLACE.

EXPANDING MANDREL.

SPECIFICATION forming part of Letters Patent No. 436,223, dated September 9, 1890.

Application filed January 31, 1890. Serial No. 338,743. (No model.)

To all whom it may concern:

Be it known that I, JOHN T. EVELY, a citizen of the United States, residing at Washington, in the District of Columbia, have invented certain new and useful Improvements in Expanding Mandrels; and I do hereby declare the following to be a full, clear, and exact description of the invention, such as will enable others skilled in the art to which it appertains to make and use the same.

My invention relates to mandrels of the kind known as "expanding mandrels" for holding and centering tubular articles to be turned; and the object of my improvement is to produce an expansible mandrel of great rigidity and strength adapted for convenient application and adjustment to and within the article to be turned, and for being readily removed therefrom, to render its holding and clamping function firm and secure, and to adapt its construction with special reference for supporting heavy ordnance to be turned.

In the new construction which I have devised provision is made whereby the mandrel is secured to the article by an outward-drawing action of an expansible sleeve-bearing upon a conical body, and provision is made whereby the mandrel is released by an inward movement of such sleeve-bearing, or by the conjoint action of both, and in which such securing and releasing action of the parts is effected quickly by means of screw-bolts arranged to act with an outward pulling force and independent screw-bolts arranged to act with an inward pushing force.

My invention also provides for locking the expanding sleeve to the conical mandrel-body to prevent the turning of the sleeve with the cannon upon the conical body independent of the latter.

The present practice of centering and supporting heavy ordnance to be turned is to provide turned solid center plugs and drive them tightly into the open ends of the cannon, and thereby form solid closed ends for the bore, provided with the usual mounting centers for the lathe; but in this plan great difficulty is

experienced in removing the plugs from the bore of the cannon. Moreover, the driving in and driving out of such solid center plugs are attended with more or less injury to the rifl-bore of the cannon and to the ends of the cannon-bore, and the labor and time in driving these solid plugs into the bore and the great trouble of removing them therefrom are serious objections to this plan.

I have used my expanding mandrel in different sizes to suit heavy ordnance of different sizes of bore, and find it comparatively easy and expeditious in securing them within the bore of the cannon with a perfect and firm hold and in removing them therefrom without the slightest marring of the bore.

The special matter of novelty of construction and of combinations in my expanding mandrel I will now describe, and embrace in distinct claims concluding this specification, in connection with the accompanying drawings, in which—

Figure 1 represents in elevation my improved expanding mandrel and the manner of applying it within the bore of a cannon, which is shown broken away for the purpose of such illustration. Fig. 2 is a longitudinal axial section of the same, taken through one of a set of bolts which act with an outward pulling force upon the expanding sleeve. Fig. 3 is a similar section taken through a set of bolts which act with an inward releasing force upon the expanding sleeve. Fig. 4 is a similar section taken through a set of bolts which act with an outward pulling force upon the mandrel-body independent of the expanding sleeve. Fig. 5 is a transverse section taken through the expanding bearing of the mandrel. Fig. 6 is a view of the outer head end of the mandrel. Fig. 7 is a view in perspective of the expanding split sleeve, showing its relation to the ring and its connected bolts for drawing the sleeve upon the conical body of the mandrel. Fig. 8 is a view of the grooved conical mandrel-body, and Fig. 9 shows the ring-follower of the sleeve.

The body *a* of the mandrel is of sufficient

length to form a rigid support for the ends of the cannon, there being one for each end of the cannon. This body tapers inward from an annular head *b*, formed with it, and which
5 contains the separate sets of operating-bolts for securing and releasing the expanding mandrel, and the socket *c* for the lathe center, while a cylindrical stem *d* projects from the inner end of the conical body, for a purpose to be presently stated.

A sleeve *e* is accurately tapered and ground on its inner side to fit upon the conical body, and is of a length a little greater than the body, while its outer side is of uniform diameter throughout its length, and is also ground
15 to fit and bear equally at all points within the bore of a cannon. The sleeve is split longitudinally at *f* to permit of its expansion and of being forced upon the conical body, while by means of longitudinal kerfs *g* such expansion is made uniform when drawn upon the conical body to secure it within the bore, which operation is effected as follows: Equidistantly on the surface of the conical body
20 are formed longitudinal grooves *h*, of semi-circular cross-section, and corresponding longitudinal grooves *i* are formed on the inner wall of the split sleeve to receive screw-bolts *j*, the screw ends of which pass through holes
30 *k* in the annular head of the conical body to receive nuts *l*, which bear upon the outer face of the said head. A ring *m* is fitted upon the inner headed ends of these bolts, and is centered upon the cone-stem *d* against the
35 inner end of the split sleeve, and is of a diameter a little less than that of the sleeve, so that the drawing of the bolts outward by their nuts forces the ring against the inner end of the split sleeve and slides it outward upon
40 the cone, thus expanding the ring and binding it hard within the bore. As these bolts fit alike in the coincident grooves of the conical body and the split sleeve, they serve to lock these two parts together and prevent one
45 from turning upon the other. As this construction requires the split sleeve to be held upon the conical body at a point that will permit it to be easily inserted within the bore, I provide for contracting the sleeve and holding it
50 to reduce its circumference by means of a spanner-claw *n*, which is placed across the split of the sleeve with its ends clamped against the radial longitudinal walls of recesses *s*, made by depressions in the surface
55 of the sleeve, the said depressions terminating at the surface, so as to form inclined bottoms, which act to automatically raise and displace the spanner-dog as the mandrel is moved into the bore, with the said spanner against the
60 end of the cannon, as seen in Fig. 1. In this operation the spanner-claw is caused to slide over the walls, which it grasps, to the ends of the depressions, at which points the spanner is forced by its holding ends riding on the
65 bottoms of the depressions to slip off and allow the sleeve to expand. The nuts *l* are then turned equally in regular order to draw the

three bolts *j* outward and with them ring-follower *m*, forcing the sleeve hard upon the conical body and expanding it hard against
70 the walls of the bore to securely fasten the mandrel to the cannon.

To prevent the bolts *j* from turning with the nuts *l*, I make them square at their heads, and thereby lock them by square holes *t* in the
75 follower-ring.

I provide two sets of bolts as the means for removing the mandrel—an outer set *u* and an inner set *v*—which may be used conjointly or
80 separately. The outer set *u* is arranged in threaded holes in the annular head to bear against the end of the cannon as an abutment and when turned by their heads exert an outward force upon the conical body to draw it
85 from the sleeve, which is held bound in the bore. The inner set *v* is arranged in threaded holes in the annular head to bear against the outer end of the split sleeve, and these screws, being supported in the annular head as an
90 abutment, exert an inward force to drive the sleeve inward toward the small end of the conical body. In this action the nuts of the outward-drawing bolts *j* are loosened to allow
95 the sleeve to be moved inward. Should the outer set of bolts *u* fail to start and draw the conical body outward, then the bolts *v* are brought into action to start and force the sleeve inward, and thus in either case allow
100 the sleeve to contract and be released from its holding function within the bore.

I claim as my improvement—

1. In an expanding mandrel, the combination, with the conical body having an annular head provided with equidistant holes, a split sleeve upon said cone, and a ring-follower at
105 the inner end of said sleeve, having holes corresponding to the holes in the head, of the bolts *j*, passing through said holes and provided with nuts *l* on their outer ends, substantially as described, for the purpose specified.
110

2. The combination, in an expanding mandrel, of the conical body having an annular head provided with equidistant holes, a split sleeve upon said mandrel, the ring-follower,
115 the bolts *j*, passing through holes in the latter and in said head, and the nuts *l*, for operating said bolts, with the outer set of screw-bolts *u*, working in tapped holes in said head, arranged to bear upon the article being
120 turned, substantially as described, for the purpose specified.

3. The combination, in an expanding mandrel, of the headed conical body, the split ring, the ring-follower, the nutted bolts connecting the head of the conical body and the
125 said follower, and the outer set of screw-bolts *u*, working in tapped holes in said head, arranged to bear upon the article being turned, with the inner set of screw-bolts *v* arranged
130 to bear upon the outer end of the split ring, substantially as described, for the purpose specified.

4. In an expanding mandrel, the combina-

tion of the conical body having an annular head, a split sleeve provided with surface recesses on each side of the split, a ring-follower, and bolts passing through holes in the
 5 follower and in the head, with a spanner-claw *n*, adapted to span the sleeve-split and hook over and upon the radial walls of the recesses for holding the said sleeve contracted while the mandrel is being inserted into the bore
 10 of the article to be turned, as set forth.

5. In an expanding mandrel, the conical-headed body formed with longitudinal surface grooves *h* of semicircular cross-section, in combination with a split sleeve formed with
 15 coincident longitudinal grooves *i* on its inner wall, the ring-follower, and the nutted bolts passing through said ring-follower, the coincident grooves in the cone and the sleeve, and through holes in the said cone-head, where-
 20 by the sleeve and the cone are prevented from

turning independently of each other, substantially as described.

6. The combination, in an expanding mandrel, of the conical body having an annular head, the split sleeve, and means, substan- 25 tially as described, for drawing it outward upon the cone to expand said sleeve, with means for releasing the mandrel from the bore, consisting of an outer set of screw-bolts *u*, exerting an outward pulling force to with- 30 draw the conical body, and an inner set of screw-holes *v*, exerting an inward pulling force to drive off the sleeve, as set forth.

In testimony whereof I affix my signature in presence of two witnesses.

JOHN T. EVELY.

Witnesses:

ARTHUR BROWNING,
 LAMECH DUVALL.